

BOAC

Battery Operated Alarm with Charger

FEATURES:

- 12V Battery Charger
- Power Loss Alarm with Enable/Disable Mode Switch
- Push-To-Test Switch
- Repeat Cycle Timer for Horn

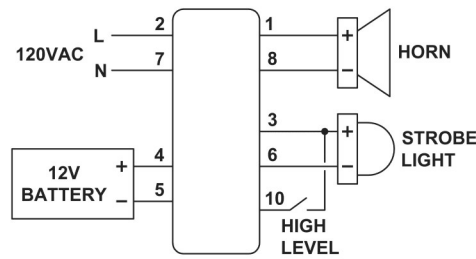

UL FILE # E101681

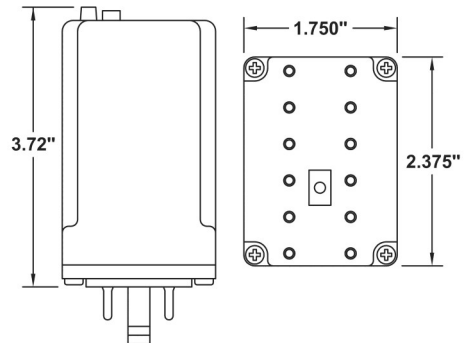
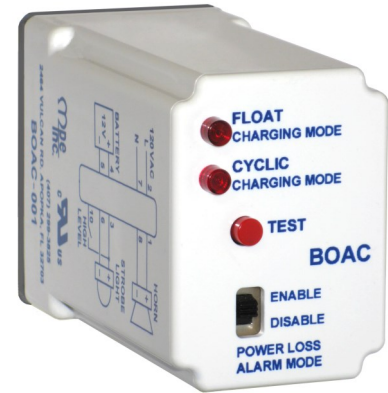

OPERATION

The BOAC is a device that performs the various tasks required to manage a 12VDC alarm system that has an alarm strobe light and horn powered by a 12V backup battery. The BOAC charges the backup battery, provides a Power Loss Alarm (when required), has a repeat cycle timer for the horn, a system push-to-test button and indication of the battery charging mode.

During an alarm condition the alarm strobe light and horn are powered by the battery. After an alarm condition and with 120VAC applied/restored, the BOAC will recharge the 12V backup battery. During an alarm condition battery power is conserved by operating the horn intermittently, on for 2 seconds, and then off for 2 seconds.

Upon closure of an alarm contact across pins 3 and 10, the strobe light and horn will be activated. Also, upon the loss of 120VAC power, the Power Loss Alarm (if enabled) will activate the strobe light and horn. The Power Loss Alarm may be enabled/disabled by setting the Power Loss Alarm Mode switch to the desired setting.

The push-to-test button is provided to verify system operation. When pushed, the battery charger is turned off so that the strobe light and horn may be powered solely by the battery during the test.

The BOAC utilizes a Battery Charge Controller IC chip that was specifically designed to manage the charging of sealed lead-acid batteries. This chip carefully controls the charging current and voltage during the charging process to maximize battery capacity and life. The Charge Controller has two charging modes, "Cyclic Charging" and "Float Charging". During an alarm event, the strobe light and horn will slowly run down the battery. As long as the battery voltage stays above 12.1V (50% charged), the Charge Controller will stay in the Float Charging Mode. In the Float Charging Mode, the battery will be recharged to 13.6V ± 1% @ 25°C, when the alarm clears. If the alarm were to be turned on often enough (or stay on long enough) to run the battery down below 12.1V (50% charged), the Charge Controller will toggle into the Cyclic Charging Mode and recharge the battery to 14.6V ± 1% @ 25°C. After a period of time in the Cyclic Charging Mode with no alarm events, the charging current will drop below 25 mA, and the Charge Controller toggles back to the Float Charging Mode. Battery manufacturers typically recommend this dual voltage charging regiment to ensure the optimum capacity and life of their batteries. To accommodate lead-acid battery chemistry, the Charge Controller also adjusts the charging voltage to account for changes in the ambient temperature (-20.7 mV/C° or -11.5 mV/F°).

SPECIFICATIONS

Input Power:	120 VAC ± 10% 8.9 VA max
Charging Voltage:	Cyclic Charging Mode - 14.6V ± 1% @ 25°C Float Charging Mode - 13.6V ± 1% @ 25°C
Charging Current Limit:	103mA
Strobe Light Output:	12VDC @ 500mA or Less
Horn Output:	12VDC @ 500mA or Less (See Note on Horn Selection)
Operating Temp:	-20°C to +60°C
Storage Temp:	-45°C to +85°C
Enclosure:	Lexan
Plug In Base:	Phenolic

ORDERING INFORMATION

Part Number:
BOAC-001

BOAC

Battery Operated Alarm with Charger

APPLICATION EXAMPLE

The following is an example of how a pushbutton and relay may be connected to the BOAC to provide an alarm horn silence feature:

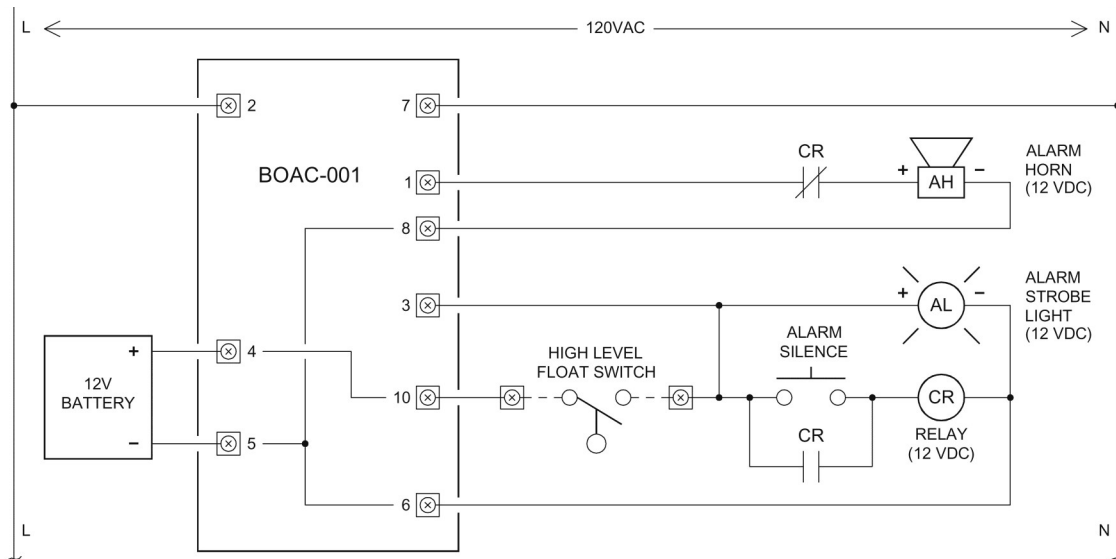

Notes:

Alarm Silence - In the above example, when there is an alarm condition, pressing the “ALARM SILENCE” pushbutton will energize the control relay (CR) and remove power from the alarm horn. The above circuit has a latch feature formed by having a contact from the control relay wired across the pushbutton. Since the latch is broken when the alarm condition clears, the horn will sound again if the alarm condition returns.

Alarm Light Output Pins 3 & 6 - With the Power Loss Alarm Enabled and upon a loss of 120VAC, the BOAC will provide +12V battery power to Pin 3 to turn on the strobe light. Also, upon a high level alarm, the +12V battery power from Pin 10 will be connected to the strobe light. Pin 6 is connected internally to the battery negative from Pin 5.

Alarm Horn Output Pins 1 & 8 - With the Power Loss Alarm Enabled and upon a loss of 120VAC, the BOAC will provide +12V battery power to Pin 1 to turn on the alarm horn. Also, upon a high level alarm, the +12V battery power from Pin 10 will be connected through the high level float switch to Pin 3. With power connected to Pin 3, the BOAC will turn on the alarm horn output. The output to the horn is always operated intermittently, on for 2 seconds, and then off for 2 seconds. Pin 8 is connected internally to the battery negative from Pin 5.

Alarm Horn Selection - An Electronic or Piezoelectric type horn (such as the Wheelock MT-12/24-R) is required for use with the BOAC. Vibrating electro-mechanical type alarm horns create damaging high voltage transients which cannot be mitigated without affecting the

Parts Typically used with BOAC-001

Description

Battery, Sealed Lead Acid, 12V, 7Ah
Alarm Horn, Multitone Electronic, 12-24VDC, Red
Alarm Horn Back Box, Red
Alarm Strobe Light, 12-48VDC, Red
Socket (for BOAC-001), 12Pin, Surface Mount, 10A, 600V

Manufacturer

EnerSys
Wheelock
Wheelock
Federal Signal
Custom Connector

Part Number

NP7-12
MT-12/24-R
IOB-R
LP3M-012-048R
SD12-PC