

TRANSDUCER SURGE ARRESTER

DESCRIPTION

The Transducer Surge Arrester (LM SURGE) is a Din-Rail mounted Surge Protection device, providing effective protection of the 4-20mA loop while taking only minimal space within the control panel.

The LM Surge product can protect two 4-20mA signals, one signal protected via pins 1,1' and 2,2' and a second signal protected by pins 3,3' and 4,4'. The LM Surge product can be used in both standard and intrinsically safe applications. The LM Surge product is not an Intrinsically Safe Barrier, but has been designed to provide surge protection for Zone 2 intrinsically safe applications.

The LM SURGE Arrester has a removable protection module, that can be easily removed and replaced. The functionally-optimized design contains “make before break” terminals that assure continuity of the 4-20mA signal in both the protected and unprotected state.



DIMENSIONS

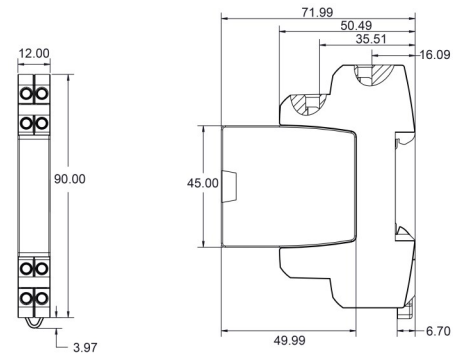

ELECTRICAL DIAGRAM

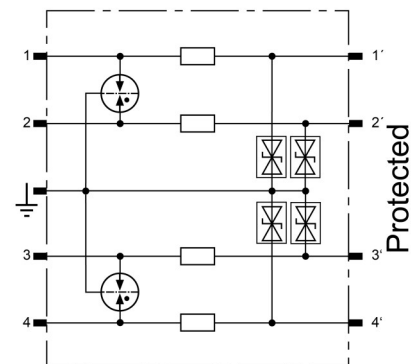

SPECIFICATIONS

Degree of Protection:	IP20
UL Rating:	UL497B
ATEX Approvals:	DEKRA 12ATEX0254 X: II 3 G Ex nA IIC T4 Gc
IECEx Approvals:	DEKRA 11ATEX0089 X: II 3 G Ex nA
Test Standards:	IEC 61643-21, EN61643-21, UL497B
IEC61643-21 Test Category:	D1, C2, C3
SIL Classification:	SIL2, SIL3
Nominal Voltage (U _N):	24V
Max. Continuous Operating DC Voltage (U _C):	33V
Grounding:	Via Din-Rail
Series Impedance per line:	1.8 Ohms
Capacitance, line to line:	≤.5 nF
Operating Temp:	-40°C to +80°C
Conductors (Flexible):	14 - 28 AWG
Dinrail Mounting Clip:	35mm
Terminal Torque:	3.5 Lb-In

ORDERING INFORMATION

Part Number: **LM SURGE**

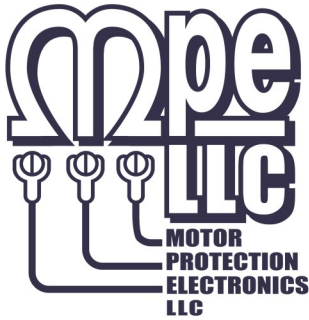

TRANSDUCER SURGE ARRESTER CONNECTION DIAGRAMS

Typical Application

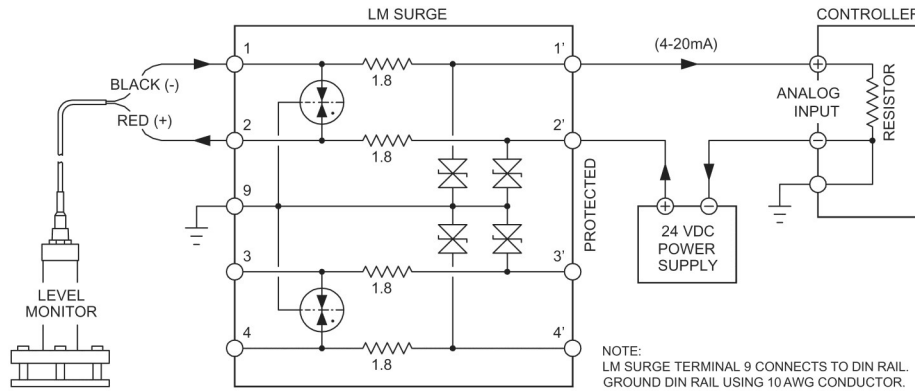

Intrinsically Safe Application

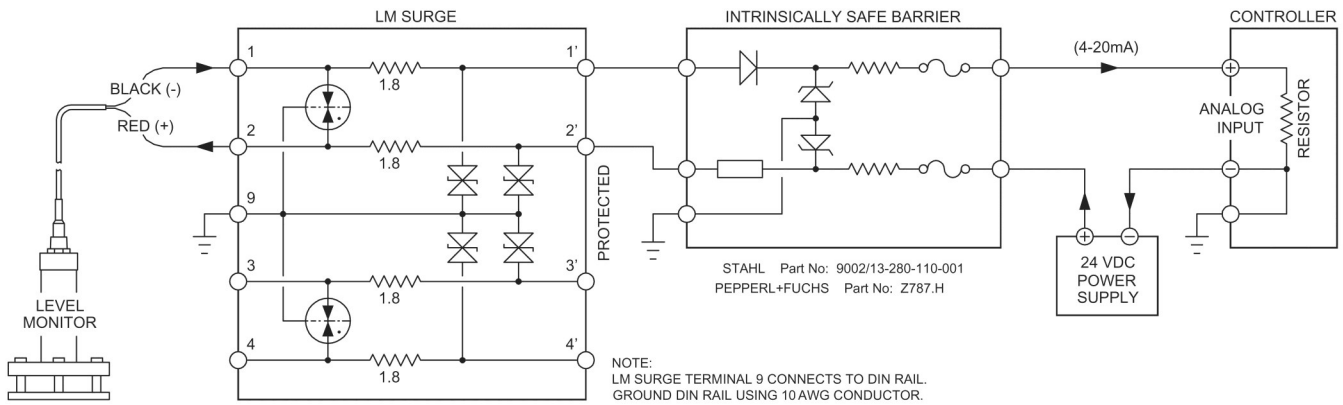

Notes for Using the LM Surge in an Intrinsically Safe Application:

1. Grounding to terminate to an equipotential bonding point. The cross section of the ground conductor from the LM Surge device to the equipotential bonding point must be 6 mm² or 10 AWG.
2. LM Surge and I.S. Barrier must be mounted in the non-hazardous location.
3. Entity parameters for the Submersible Pressure Transducer must be compatible with the entity parameters of the I.S. Barrier.
4. Ex Rating for the LM Surge product is II 3G ExnA IIC T4 Gc. Equipment in this category is intended for use in areas (other than mines) which explosive atmospheres by gases or vapors are unlikely to occur, or if they do, are likely to do so infrequently and for a short time only. The LM Surge is rated for Zone 2 application.